

E183: Total Syntheses of (-)-Phaeocaulisin A ^[1], [5]-Ladderanoic acid^[2]

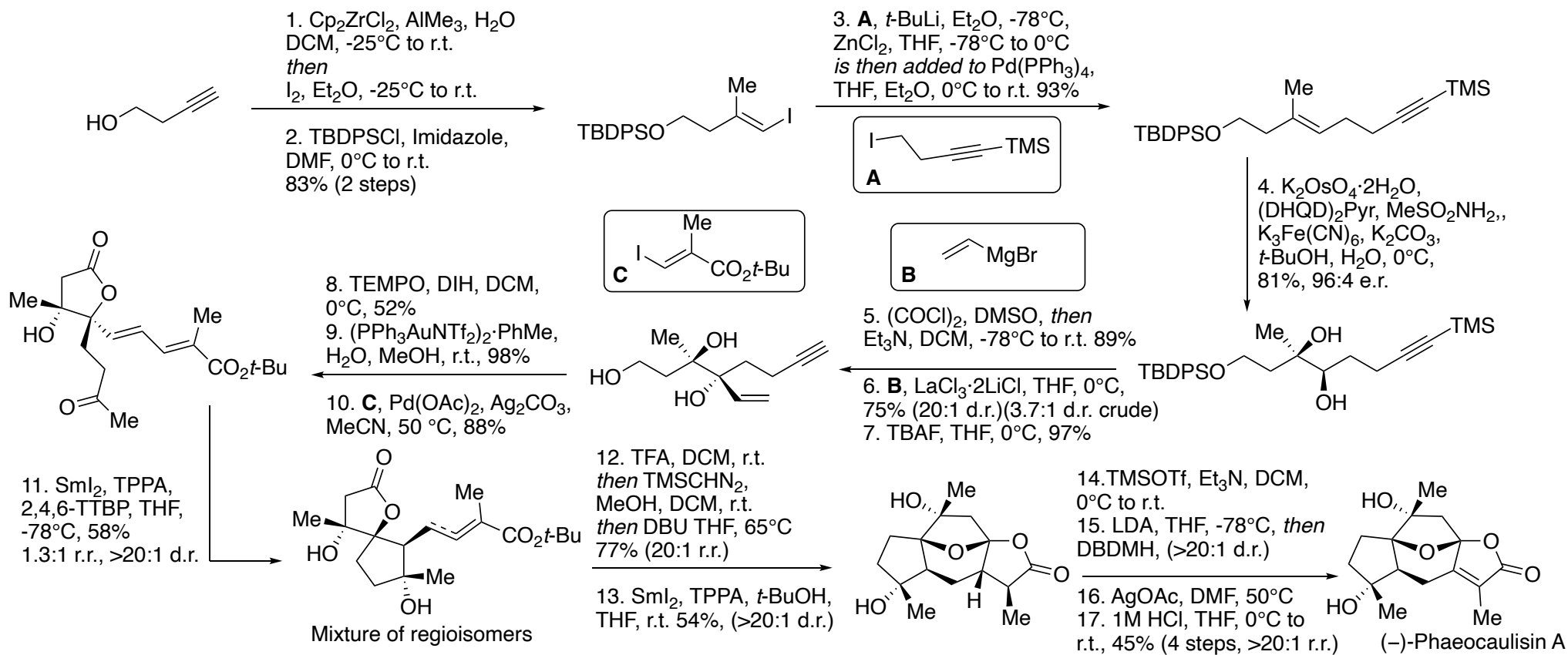

[1] A. Péter, G. E. M. Crisenza, and D. J. Procter, *J. Am. Chem. Soc.* **2022**, *144*, 7457–7464.

[2] J. A. M. Mercer, C. M. Cohen, S. R. Shuken, A. M. Wagner, M. W. Smith, F. R. Moss, M. D. Smith, R. Vahala, A. Gonzalez-Martinez, S. G. Boxer, N. Z. Burns, *J. Am. Chem. Soc.* **2016**, *138*, 15845–15848.

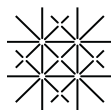

E183: Total Syntheses of (-)-Phaeocaulisin A ^[1], [5]-Ladderanoic acid^[2]

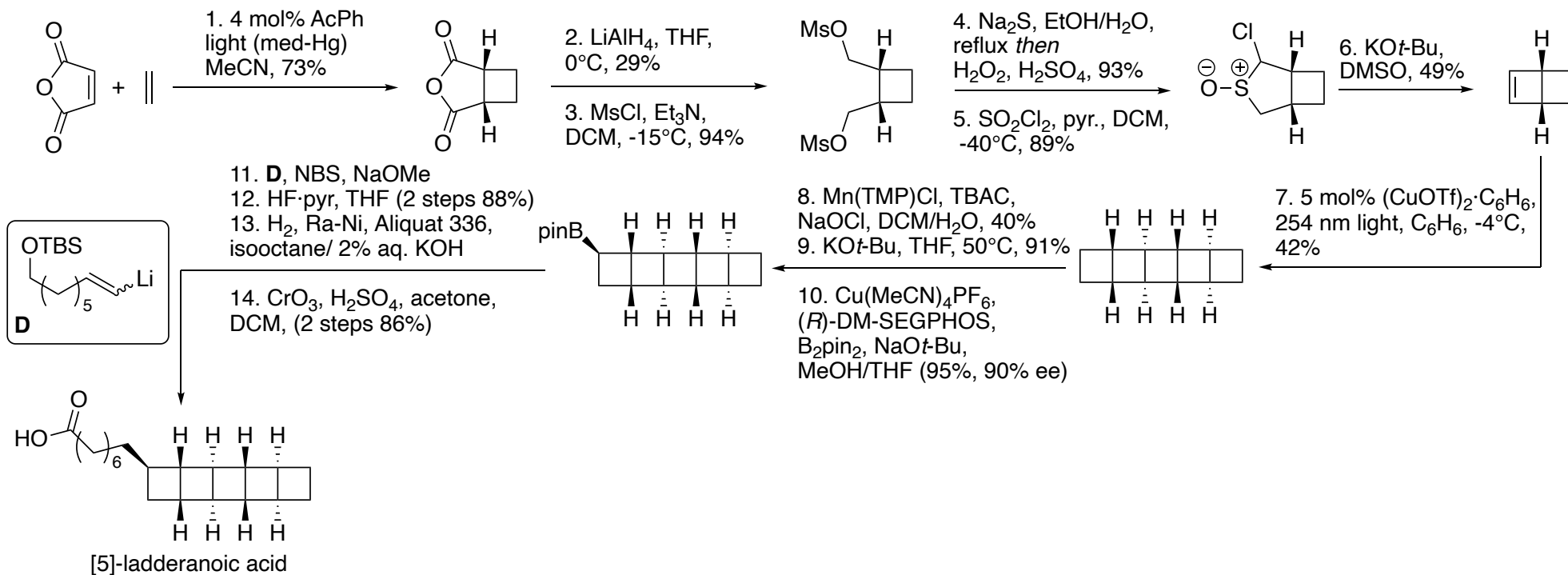

[1] A. Péter, G. E. M. Crisenza, and D. J. Procter, *J. Am. Chem. Soc.* **2022**, *144*, 7457–7464.

[2] J. A. M. Mercer, C. M. Cohen, S. R. Shuken, A. M. Wagner, M. W. Smith, F. R. Moss, M. D. Smith, R. Vahala, A. Gonzalez-Martinez, S. G. Boxer, N. Z. Burns, *J. Am. Chem. Soc.* **2016**, *138*, 15845–15848.

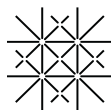

University
of Basel

Sparr Group Seminar
18.05.2022
Dragan Miladinov